

Grape/Fruit Press Instructions



Brewers *Direct*

**1400A Sargent Ave
775-9234**

**1117 St. Mary's Rd.
253-5666**

**2-1514 Regent Ave.
661-6150**

**1107 Fife St.
694-1298**

OPERATING AND ASSEMBLY INSTRUCTIONS

Component List:

1. Ratchet Inserts (Qty 2)
2. Retaining Clip
3. Washer
4. Upper Ratchet Plate
5. Threaded Inner Collar (Crown)
6. Lower Ratchet Plate
7. Threaded Shaft
8. 1/2 Cage (Qty 2)
9. Lever Pin
10. Lever Mechanism
11. Lever
12. Retaining Clip
13. Cage Locking Pin (Qty 4)
14. Wood Blocks (Qty 6)
15. Semi-Discs (Qty 2)
16. Base with Legs
17. Lower Retaining Nut

Note: Legs, base, threaded screw and ratchet mechanism come pre-assembled. Lever pin may not be inserted for shipping purposes.

Brewers *Direct*

**1400A Sargent Ave
775-9234**

**1117 St. Mary's Rd.
253-5666**

**2-1514 Regent Ave.
661-6150**

**1107 Fife St.
694-1298**

Fruit & Wine Press Exploded View

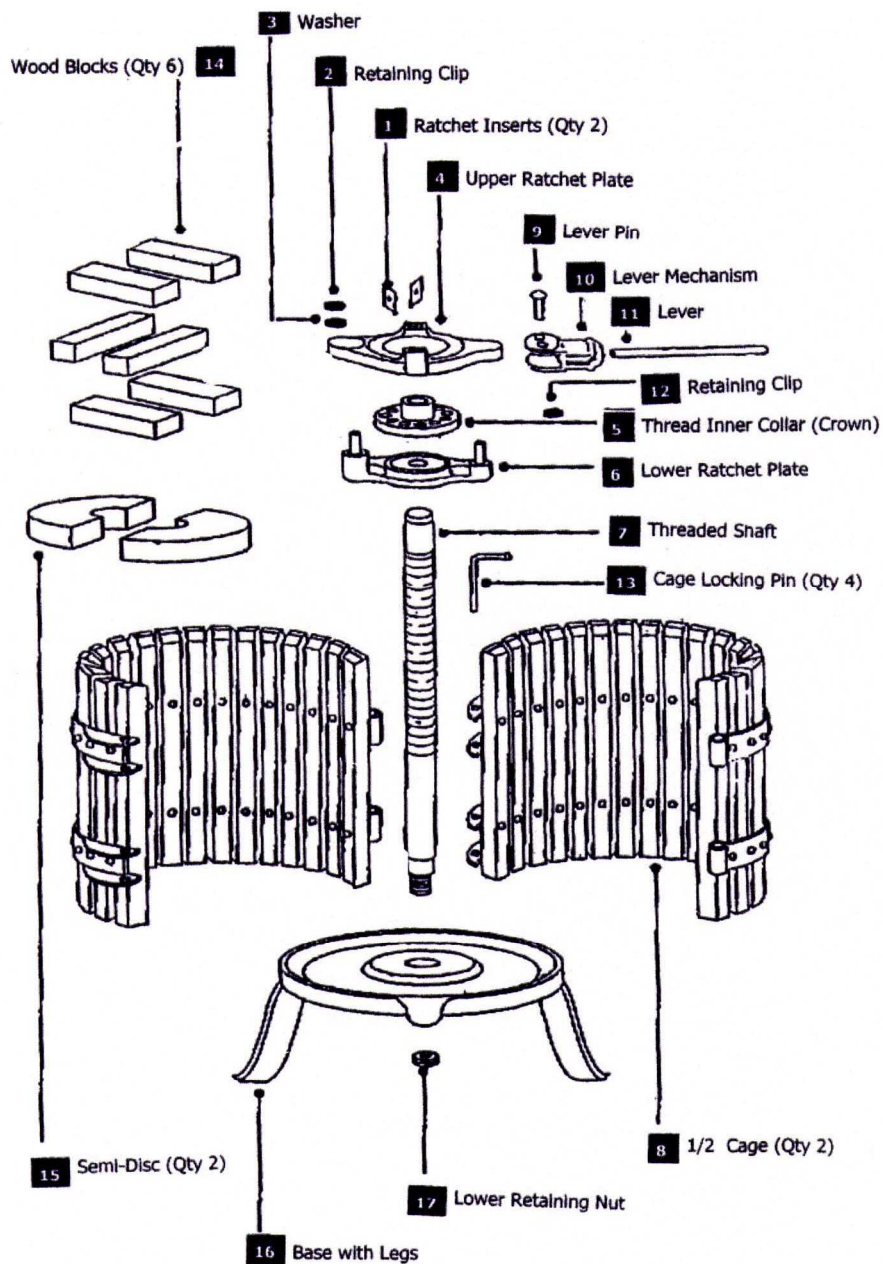

Brewers *Direct*

1400A Sargent Ave
775-9234

1117 St. Mary's Rd.
253-5666

2-1514 Regent Ave.
661-6150

1107 Fife St.
694-1298



1. Insert slightly bent end into steel band.
2. Rotate upwards

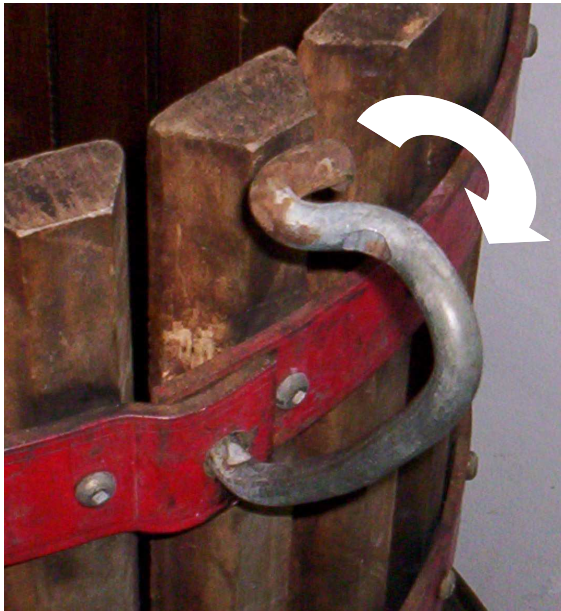

3. Once retaining pin is properly inserted into steel bands, rotate downwards, or clockwise.

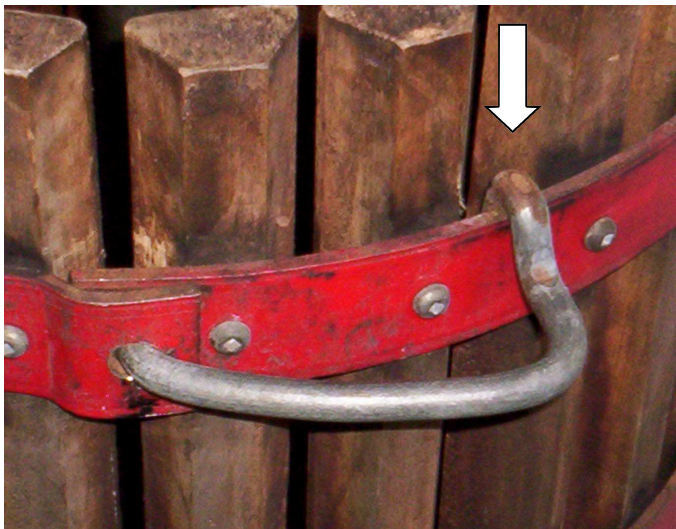

4. Lock pin over steel band.
5. Perform same operation with all the other locking pins.

If unit is received without the lever pin inserted, follow these simple directions:

1. Fully swivel the lever mechanism counter clockwise until the lever stops.
2. Raise the lower ratchet plate and lever mechanism until the slot in the lever is even with the tab on the upper ratchet plate.
3. Swivel the lever mechanism clockwise allowing the tab in the upper ratchet plate to engage the slot in the lever mechanism.
4. Continue rotating the lever mechanism clockwise slowly until the hole in the lever mechanism lines up with the hole in the tab of the upper plate.
5. Insert lever pin into the hole to lock the lever to the upper ratchet plate.

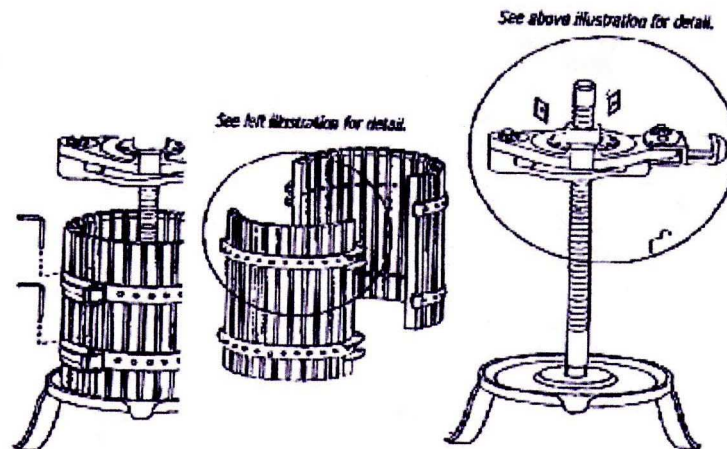
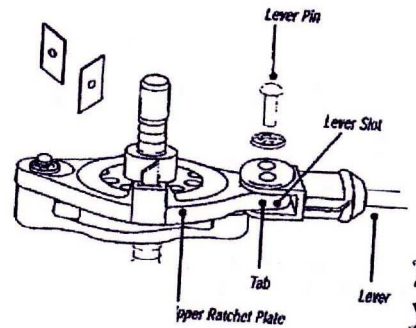

Brewers Direct

**1400A Sargent Ave
775-9234**

**1117 St. Mary's Rd.
253-5666**

**2-1514 Regent Ave.
661-6150**

**1107 Fife St.
694-1298**

Operating instructions continued:

1. Place the 1/2 cage assemblies on the base, creating circle around the threaded screw until the hinge assemblies are mated together.
2. Place a cage locking pin in each of the hinge assemblies.
3. Fill the caged area with your favourite fruit. Leave approximately 2 inches or more of space at the top of the cage area for the semi-discs.
4. Place the semi-discs on top of the fruit, allowing them to slide inside the cage.
5. Place two wooden blocks on top of the semi discs. **Note:** For best results, the blocks should be placed perpendicular to the slot in the semi-discs and kept as close to the centre screw as possible. (If a d d i t i o n a l space is still present between the ratchet mechanism and the blocks, additional blocks may be stacked on top of the first set until the space is eliminated. Each set of blocks should be stacked perpendicular to the previous set. This will ensure stability during the pressing process.

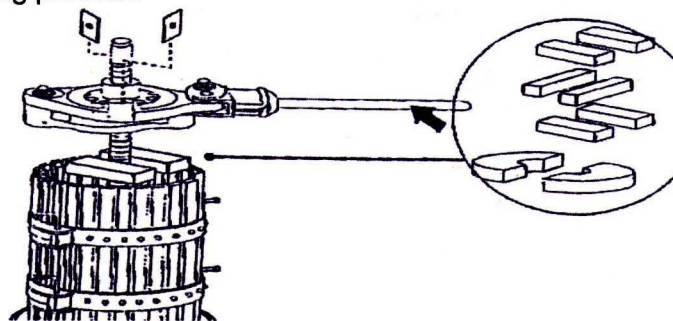
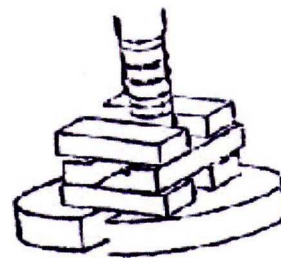
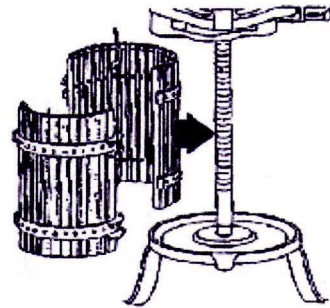

Brewers Direct

1400A Sargent Ave
775-9234

1117 St. Mary's Rd.
253-5666

2-1514 Regent Ave.
661-6150

1107 Fife St.
694-1298

Operating instructions continued:

6. Spin the entire ratchet assembly clockwise until the lower ratchet plate engages the top of the blocks. Continue to screw the ratchet assembly clockwise until you are unable to continue by hand.
7. Insert one insert into the slot closest to you with the point down to the left for pressing (down to the right for releasing). Insert the second insert in the same way. The inserts will rotate the threaded inner collar in the direction point is facing.

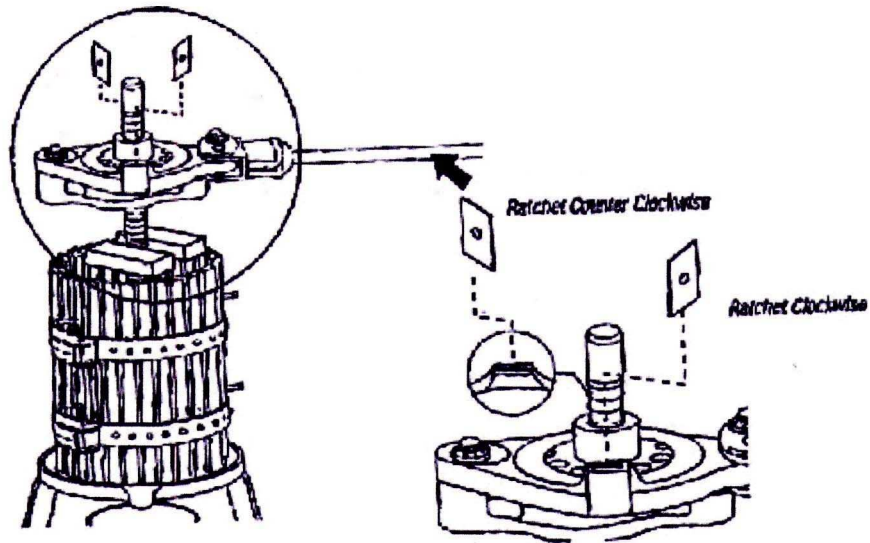
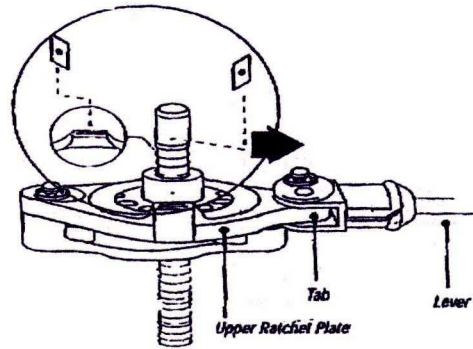

Brewers Direct

1400A Sargent Ave
775-9234

1117 St. Mary's Rd.
253-5666

2-1514 Regent Ave.
661-6150

1107 Fife St.
694-1298

HINTS FOR EFFICIENT SETUP and OPERATION OF GRAPE / FRUIT PRESS

1. Lubricate all moving parts and hinges with petroleum jelly or a food grade lubricant.
2. Place a clean sanitized container under the spout to catch the juice.
3. You may choose to line the basket with a nylon bag to contain large particles or pulp as a result of the pressing.
4. Fill the basket with grapes to within one inch of the top.
5. Place the pressing plate on the top of the grapes, followed by wood blocks placed at right angles to the plate halves.
6. Thread the ratcheting head onto the threaded shaft, set the ratchet keys to allow clockwise operation, and lower onto the wood blocks.
7. Apply pressure on the head and begin pressing by turning 2-3 turns in a clockwise direction.
8. Pause until the juice no longer runs, then continue pressing in 2-3 turn intervals.
9. Stop when the head reaches the top of the basket.
10. Reverse the ratcheting head and raise to add more wood blocks at right angles to the previous ones.
11. Lower the head to the blocks and repeat the pressing operation until all of the grapes have been reduced to 1/3 of the original volume or the ratchet turns with excessive resistance. To prevent damage to the press do not use levering devices longer than supplied with the unit.
12. Raise the ratcheting head and remove the wood blocks and pressing plate from the basket.
13. Remove the hinge pins, open the cage and remove the pomace.
14. If you wish to do a second pressing, place the pomace in a sanitized large container and break up with a ladle or large spoon and place back into the cage. Repeat the pressing cycle until all juice has been satisfactorily removed. This step is sometimes called the second run or pressing. The second pressing should be avoided if you are making wine for quality over quantity. The second pressing is of lesser quality, since some oxidization occurs and excessive tannins and harshness from the skins and pulp will be pressed into the wine.

Brewers *Direct*

**1400A Sargent Ave
775-9234**

**1117 St. Mary's Rd.
253-5666**

**2-1514 Regent Ave.
661-6150**

**1107 Fife St.
694-1298**